

DESIGNING A MODULAR PLATFORM FOR AUTOPILOT DEVELOPMENT

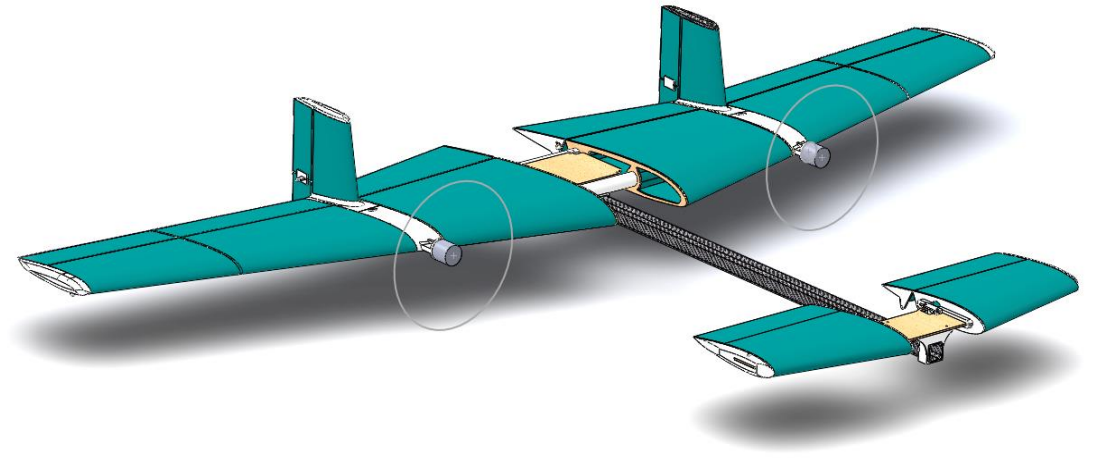
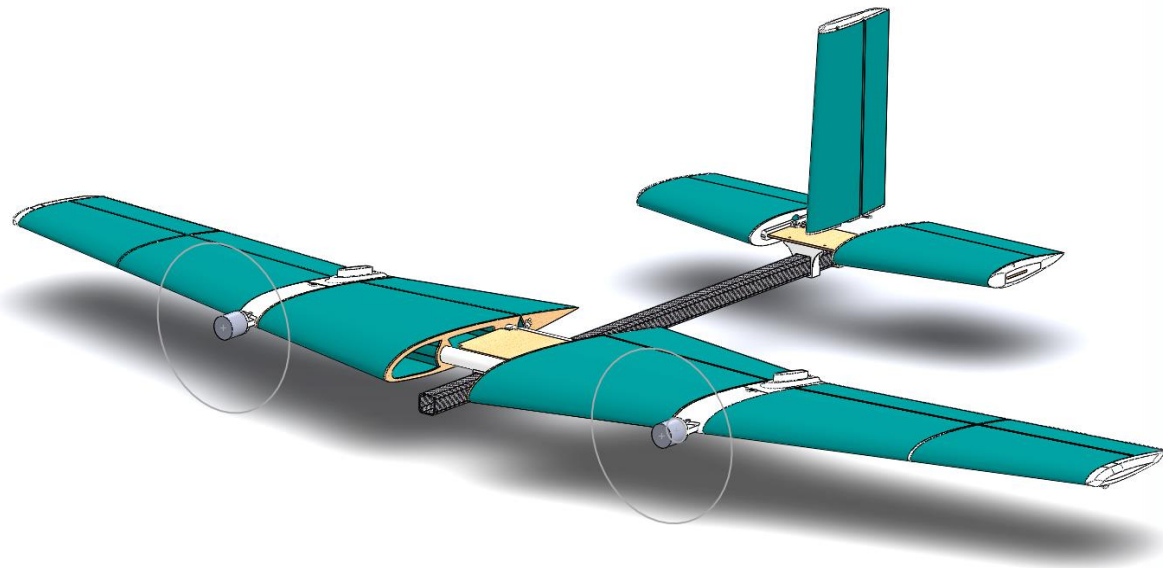

DESIGNING A MODULAR PLATFORM FOR AUTOPILOT DEVELOPMENT

Some figures :

2m wingspan

7 kilos

2 electric motors

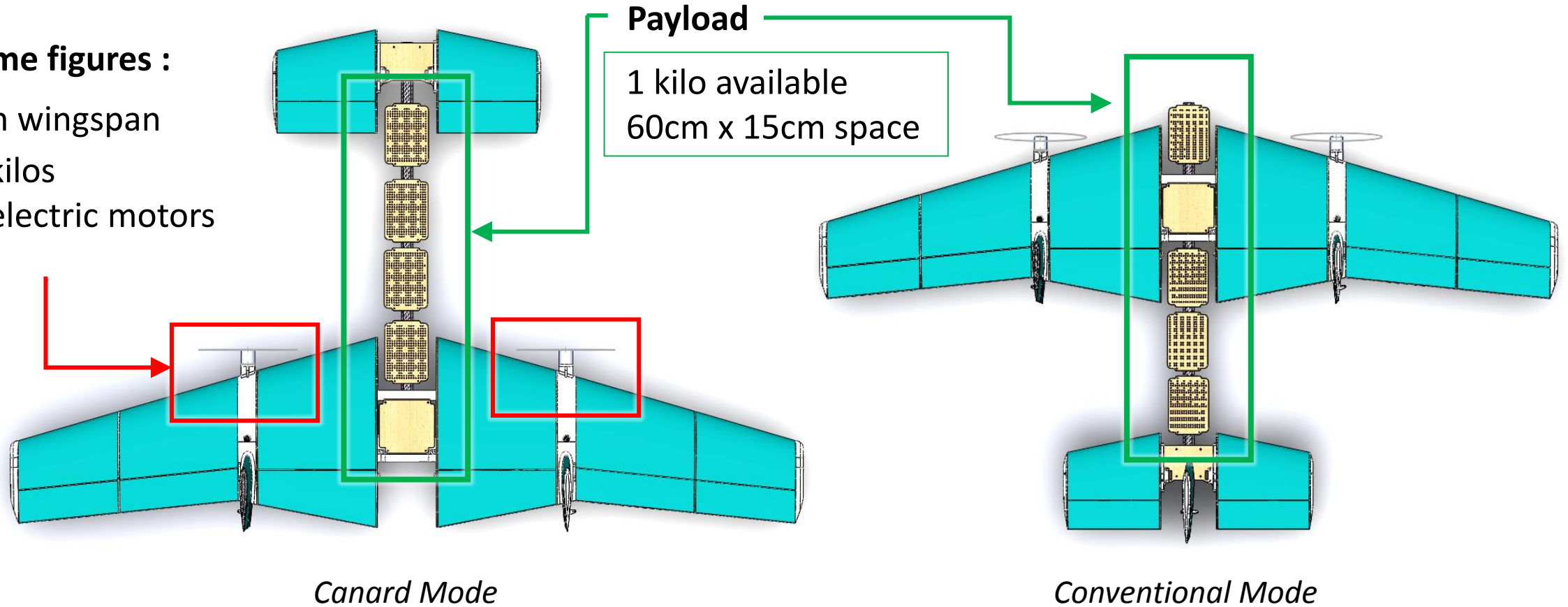

DESIGNING A MODULAR PLATFORM FOR AUTOPILOT DEVELOPMENT

Main benefits :

Tuneable CoG

Different configurations available

(Canard / Conventional)

Easy access to electronics

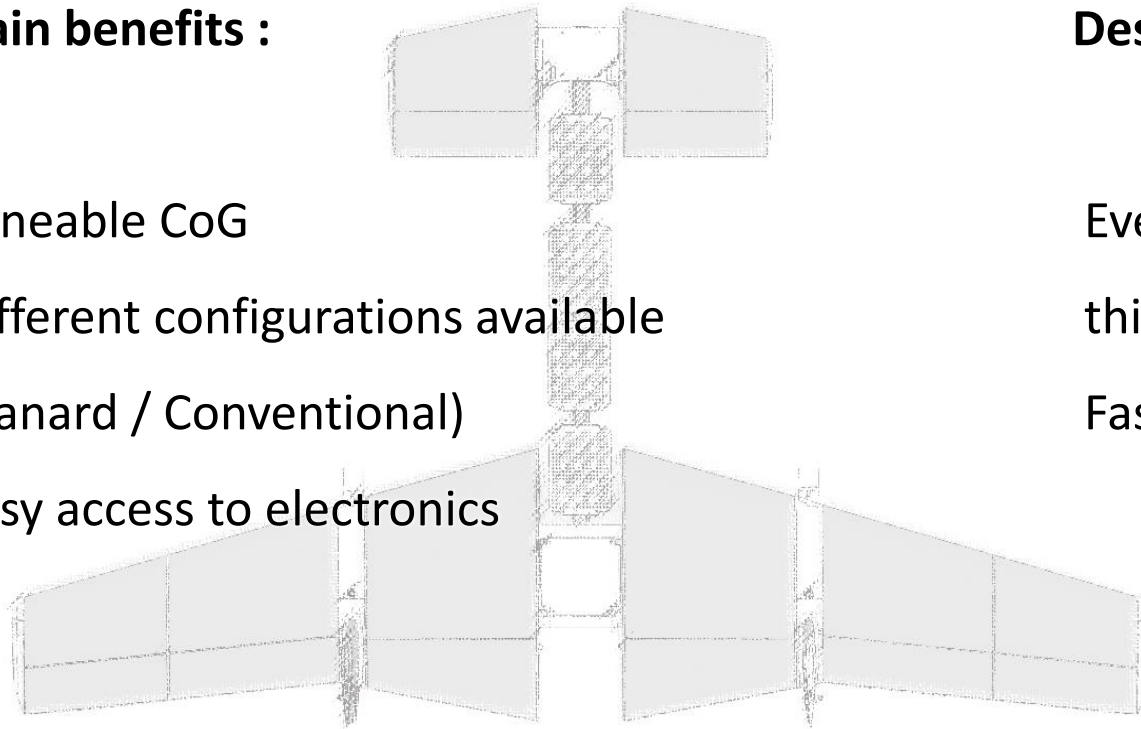

Design challenges :

Every part needs to be designed

thinking about every configuration

Fast and tool-free assembly required

